

DIGITAL CALIPER

WITH CARBIDE-TIPPED JAW

DIN
862

Battery
+
CR2032

mm
/ in

Data
output

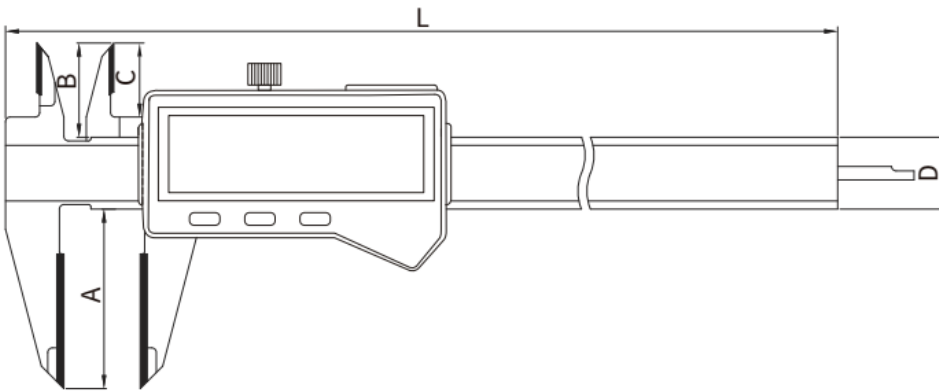

- Used to measure outside diameter, inside diameter, step and depth measurement and also for scribing
- Carbide tipped measuring faces making scribing clear and ensuring abrasive resistance
- Strictly made in accordance with DIN862
- Hardened, ground and lapped measuring surfaces for longer service life
- Measuring surfaces ground for ultimate accuracy and smooth throughout

Unit:mm

Code	Range	Resolution	A	B	C	D	L	Accuracy
2406-1005	0-150/0-6"	0.01/0.0005"	40	21	16.5	16	236	±0.03
2406-1010	0-200/0-8"	0.01/0.0005"	50	24	19.5	16	286	±0.03
2406-1015	0-300/0-12"	0.01/0.0005"	60	26	21.5	16	400	±0.04